

As per Borough ordinance

208-19

**A Zoning permit and a form inspection is
required for the replacement of the**

public sidewalks

Curbs

and

depressed curb (apron)

The fee is \$25.00

PLEASE NOTE 4 SLABS OR MORE REQUIRE

A ZONING PERMIT

**Attached you will find the concrete curb and sidewalk details
prepared by the Borough Engineering Department**

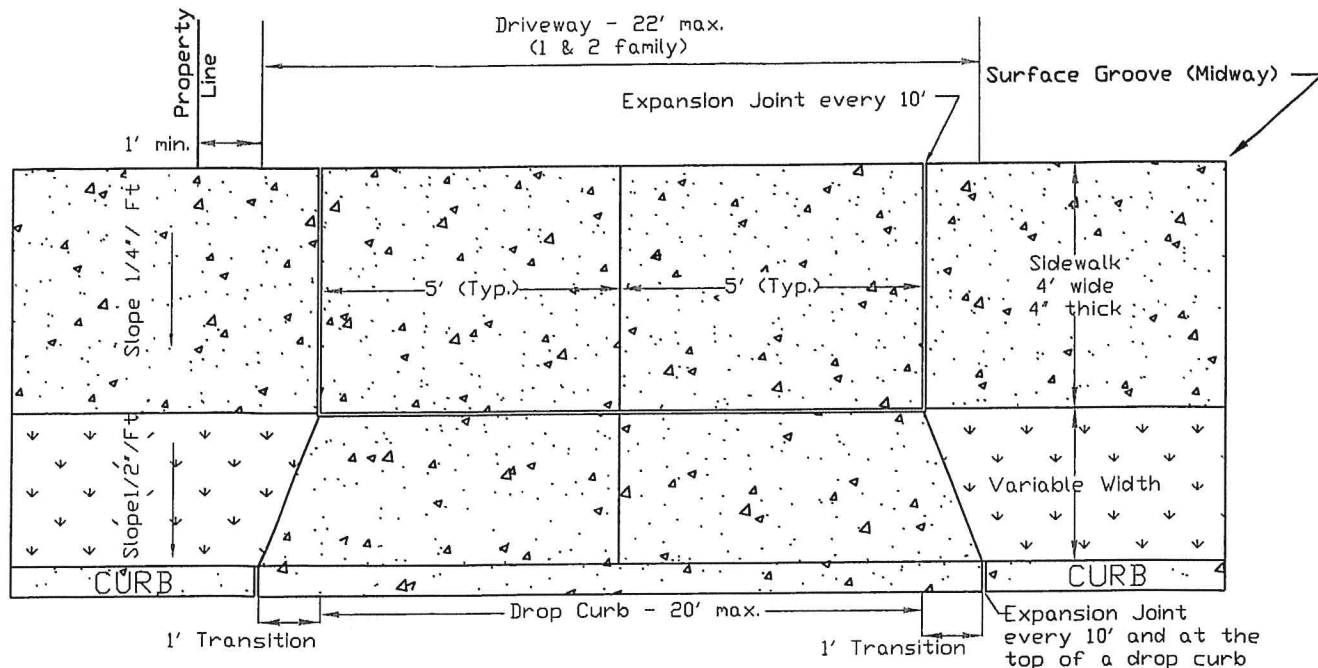

PLAN

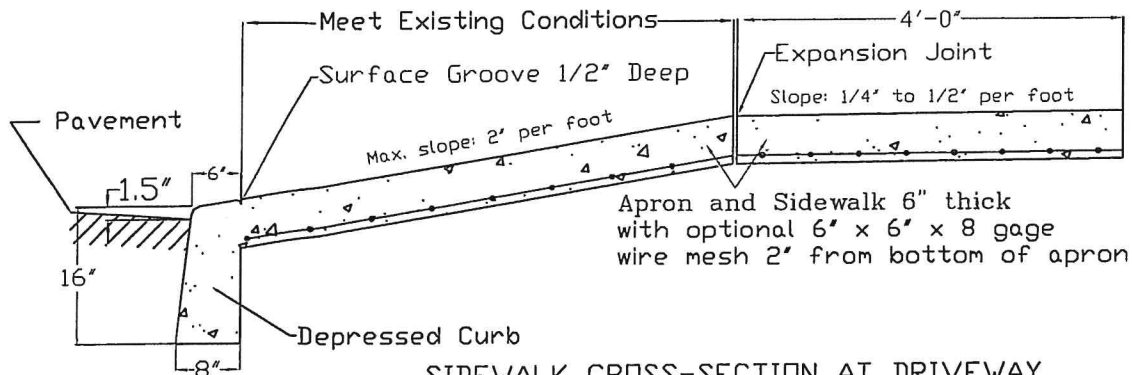

SIDEWALK CROSS-SECTION AT DRIVEWAY

Notes:

- Existing subgrade shall be compacted to 95% density or replace with compacted stone 3" thick (95% density).
- Concrete shall be Class "B", air-entrained, 3700 psl (class design strength at 28 days)
- Expansion joint material shall be 1/2" wide preformed expansion joint filler and full depth. Longitudinal expansion joints shall be provided where sidewalk abuts curb, existing sidewalk, buildings, utility structures, and where directed by the Engineer. The top of the joint filler shall be flush for curbs and slightly below the surface for sidewalks.
- Concrete edges shall be rounded with an edging tool having a radius of 1/4".
- Concrete surfaces shall be finished with a soft hair brush for curbs and a broom for sidewalks.
- All exposed surfaces are to be coated with a translucent curing compound conforming to N.J.D.O.T. Spec. 905.03 immediately following final finishing. Coverage shall not be less than 1 gallon per 200 sf.

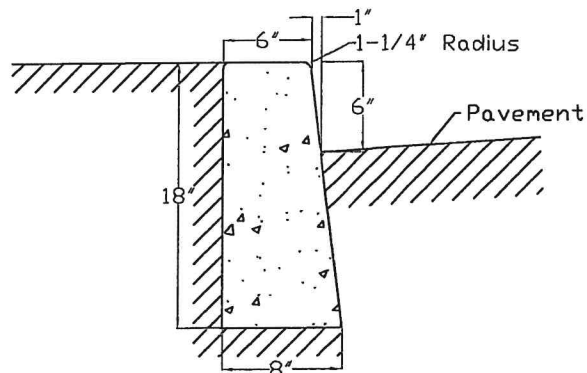

CURB

CONCRETE CURB AND SIDEWALK DETAILS

BOROUGH OF FAIR LAWN ENGINEERING DEPARTMENT

8-01 Fair Lawn Ave. 201-794-5300
Fair Lawn, NJ 07410 www.FairLawn.org

SCALE - NONE

MARCH 2002